

CHS-1

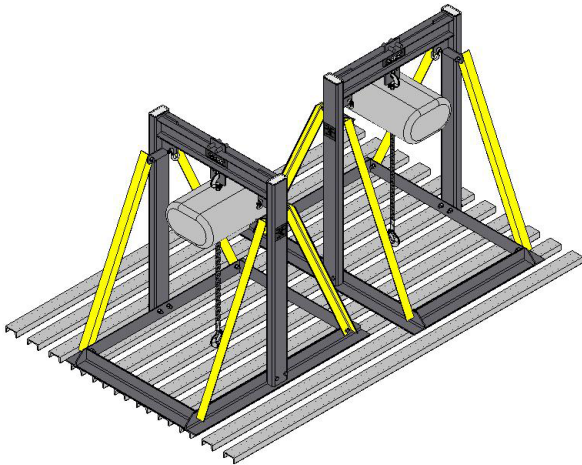

Chain Hoist Stand with Hoist



Chain Hoist on Grid

The CHS-1 Chain Hoist Stand is collapsible for easy shipment and assembly on a stage grid. Its wide footprint allows for the distribution of load on the grid surface.

Features:

- Chain hoist attachment point is adjustable to fine tune the pick point laterally within the footprint of stand
- Rigging points included to facilitate the static support of load
- Finish: black, except diagonal braces: safety yellow, to alert stage hands of trip hazards
- All fasteners Grade 5 or better

Specifications:

- Max Load capacity: 2000 lbs
- Weight: 200 lbs
- Assembled dimensions: 48" wide x 36" deep x 49 1/8" high
- Collapsed dimensions: 48 7/8" wide x 36" deep x 9 1/4" high
- Minimum opening size to pass CHS-1 components through: 36" x 8.5"

Hoist not included.

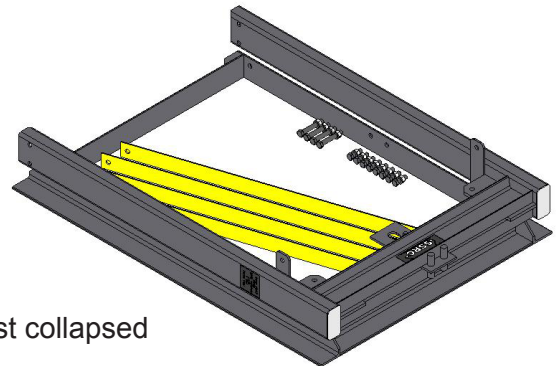

Chain Hoist collapsed