



SSRC
Quality Theatrical Distribution

**Cable
Management
System
Installation
Manual**

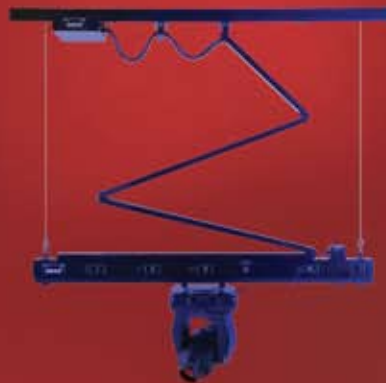



TABLE OF CONTENTS

1.0 INTRODUCTION and SAFETY 2

2.0 INSPECTION and UNPACKING..... 2

3.0 GENERAL INSTALLATION..... 2

4.0 UPPER MOUNTING 5

 4.1 Under Hung Loft Block Rigging with out Grid..... 5

 4.2 Grid Mounted..... 6

 4.3 Line Shaft Rigging with out Grid 7

5.0 BATTEN ATTACHMENT 8

 5.1 Double Pipe Batten 8

 5.2 Double Pipe Batten with Safety Guide Yokes..... 9

 5.3 Truncated Double Pipe Batten 10

 5.4 Truncated Double Pipe Batten with Safety Guide Yokes..... 11

6.0 ADJUSTMENTS 12

 6.1 End Stops 12

 6.2 Festoon – Extended..... 12

 6.3 Festoon – Retracted..... 13

7.0 CONTACTS 14

LIST OF FIGURES

Figure 1. General Arrangement and Major Components..... 2

Figure 2. Trolley Attachment Bracket and Trolley..... 3

Figure 3. Batten Attachment 4

Figure 4. Trolley Track with Under Hung Rigging 5

Figure 5. Trolley Track and Centerline of Set - Under Hung Rigging..... 5

Figure 6. Grid Mounted CMS..... 6

Figure 7. Grid Mounted CMS - End View 6

Figure 8. Trolley Track with Lineshaft Rigging..... 7

Figure 9. Trolley Track and Centerline of Set - Lineshaft Rigging..... 7

Figure 10. Double Pipe Batten..... 8

Figure 11. Double Pipe Batten with Safety Guide Yokes 9

Figure 12. Truncated Double Pipe Batten..... 10

Figure 13. Truncated Double Pipe Batten with Safety Guide Yokes 11

Figure 14. CMS in Up Position 12

Figure 15. CMS with Festoon Cables Extended..... 13

Figure 16. CMS with Festoon Cables Retracted..... 13



1.0 INTRODUCTION and SAFETY

The SSRC CMS (cable management system, aka pantograph) is a means to manage the electrical cables that feed a stage lighting batten. This can range from a few circuits to as many as 36 circuits. The CMS unit can weigh up to 500 lbs. Qualified personnel familiar with stage rigging practices should install it. As with all overhead rigging components, it is imperative that it be installed correctly to prevent injury or death. When installed correctly, the SSRC CMS is a safe, reliable system that meets or exceeds industry safety factors. The motorized rigging set upon which the CMS is to be installed must be in good working condition, have adequate capacity, and its upper and lower travel limits must be functioning correctly. The speed of the motorized set must not exceed 25 FPM (feet per minute). The rigger must have a safe means to gain access to the locations required during installation such as scaffolding or personnel lift. This manual addresses the most common integration methods with various rigging systems. Other integration techniques exist; please consult the factory for assistance or guidance.

2.0 INSPECTION and UNPACKING

Inspect shipping carton for signs of damage during delivery. Unpack unit near the installation location. Check the CMS for any visible signs of damage. If damage is observed contact the factory immediately and do not proceed with installation.

3.0 GENERAL INSTALLATION

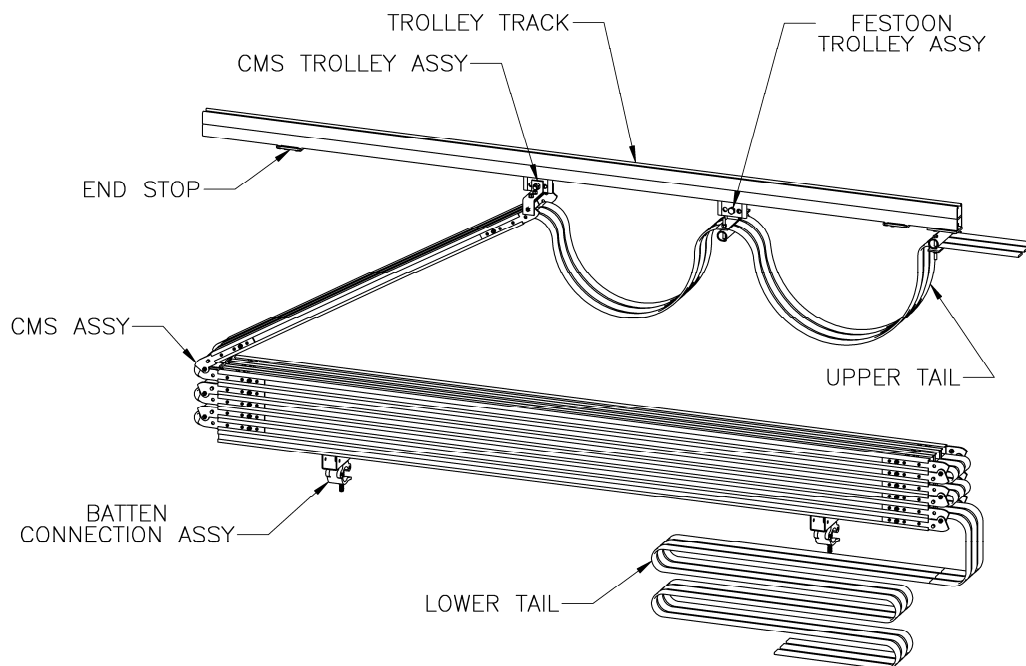

Figure 1. General Arrangement and Major Components



Locate the Trolley Track (typically a 10 ft. long section of P1001 Unistrut or equal), CMS Trolley, Festoon Trolley Assembly, and End Stops. Install the Trolley Track in accordance with one of the methods outlined in Section 4.0. The Trolley Track may need to be cut shorter to fit the particular installation conditions.

Due to the nature of the variety of installation environments, the brackets required to mount the Trolley Track are the responsibility of the Rigging Contractor or Integrator. These are not provided by SSRC, as there are an infinite number of variations. The integrator, who is intimately familiar with the field conditions of the project, is most suited to provide the CMS Track Hanger Brackets. Each bracket must be designed to support the entire weight of the CMS with an appropriate factor of safety. During the planning phase of a project, SSRC is available to provide suggestions on these brackets.

Load the CMS Trolley and Festoon Trolley into the track. See Figure 1. Make sure the Festoon Trolley is oriented correctly in relation to the CMS Trolley to manage the swag of the cable bundles as they exit the top of the CMS. Install the End Stops. Torque the End Stop bolts to 25 ft-lbs.

After the trolley track is correctly installed, raise the top section of the CMS, while allowing the lower sections to unfold, to a position where the Trolley Attachment Bracket can be attached to the CMS Trolley. Insert the 1/2 inch bolt through the bracket and trolley. Torque the 1/2 inch Nyloc to 50 ft-lbs. See Figure 2.

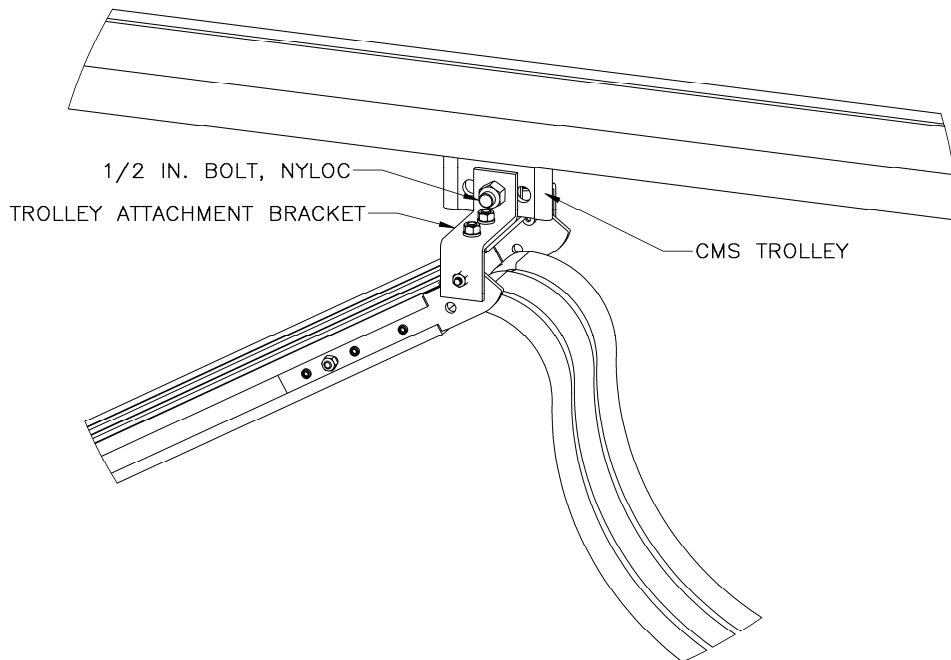

Figure 2. Trolley Attachment Bracket and Trolley



Install the Batten Connection Assemblies in the lowest section of the CMS. These should be placed approximately 15 inches from each end of the CMS section housing. Torque the 5/16 bolts securing the tube to the CMS Housing to 15 ft-lbs. Place the CMS on top of the pipe batten and secure the batten clamps. Torque the 1/2 inch nut of the batten clamps to 15 ft-lbs. The batten supporting the CMS must not be allowed to rotate. See Figure 3.

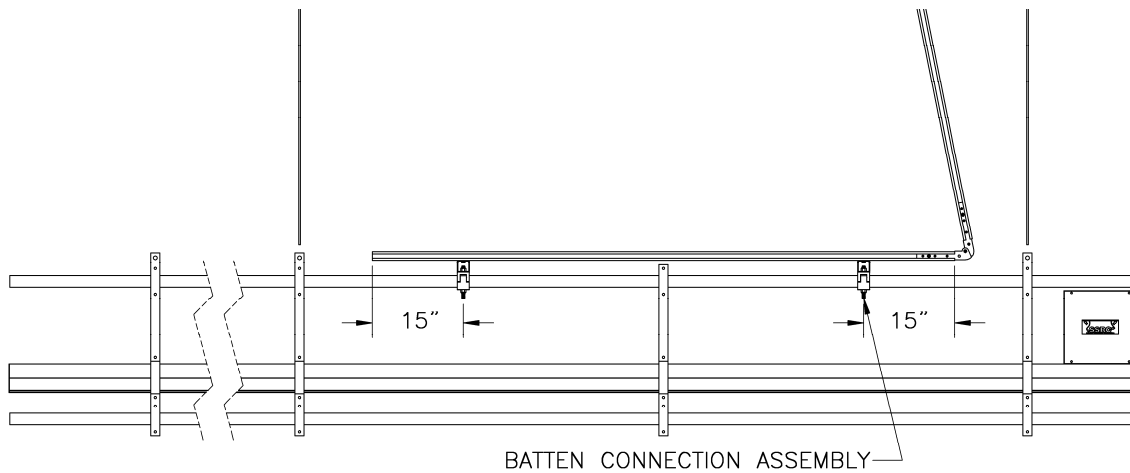

Figure 3. Batten Attachment

4.0 UPPER MOUNTING

4.1 Under Hung Loft Block Rigging with out Grid

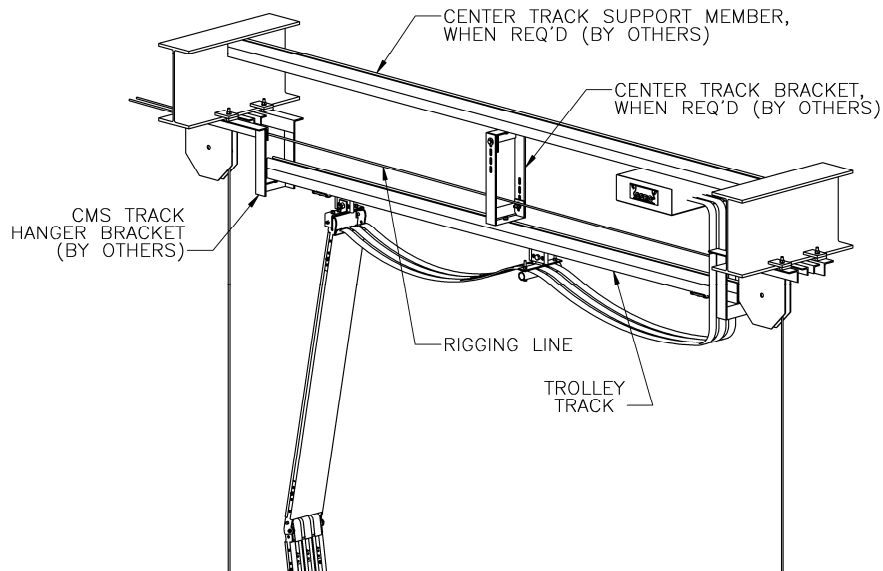

Figure 4. Trolley Track with Under Hung Rigging

The Trolley Track must be installed in the same plane with the lifting lines of the set and below the horizontally running lines. See Figure 4 and Figure 5. Custom brackets to support the trolley track are usually required. Each track support bracket must be rated for a 500 lb working load. **NOTE:** If the weight of the CMS is in excess of 200 lbs, the Trolley Track must have an additional support at its center span. Depending on the structural environment, this may require a supplemental support member (such as P1001 Unistrut or equal) to support the Center Track Bracket.

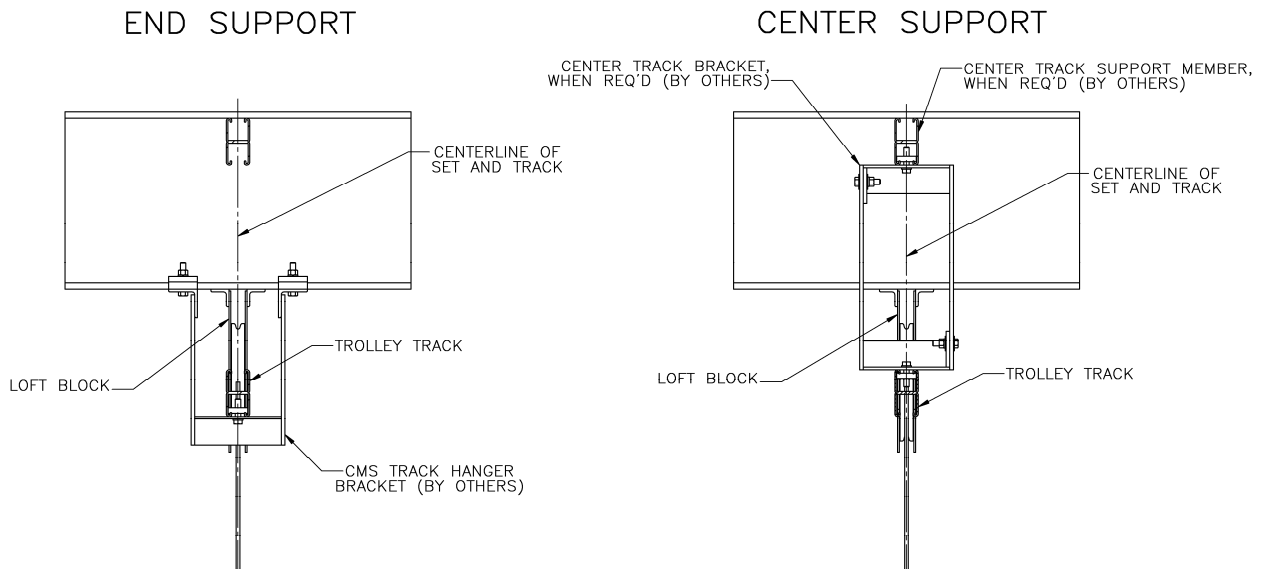

Figure 5. Trolley Track and Centerline of Set - Under Hung Rigging

4.2 Grid Mounted

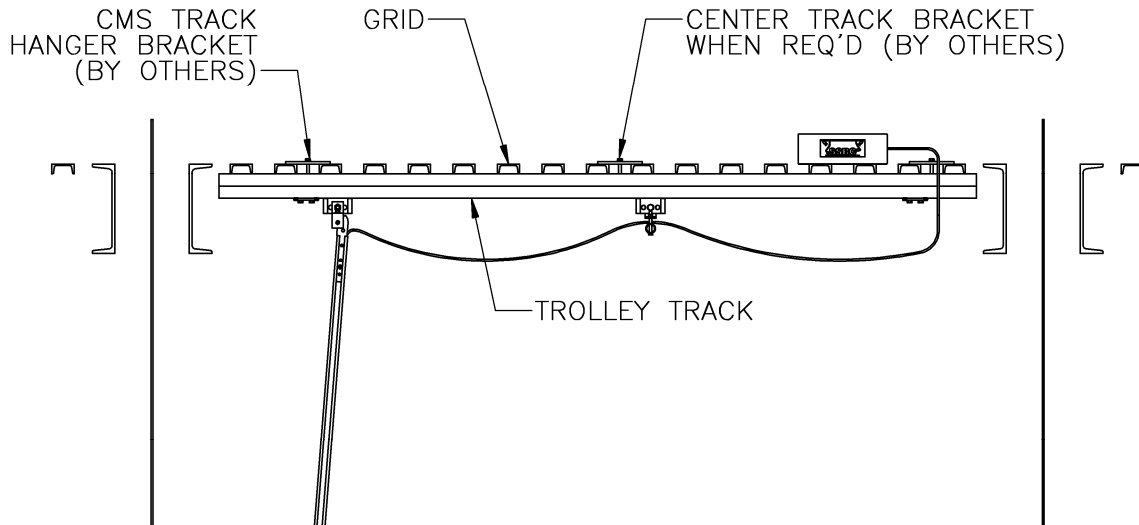

Figure 6. Grid Mounted CMS

The Trolley Track must be installed in the same plane with the lifting lines of the set and below the Grid. See Figure 6 and Figure 7. One suggested mounting method utilizes a flat plate large enough to span the grid members with a through bolt into a strut nut secured by the trolley track. Each track support bracket must be rated for a 500 lb working load. **NOTE:** If the weight of the CMS is in excess of 200 lbs, the Trolley Track must have an additional support at its center span. Depending on the structural environment, this may require a supplemental support member (such as P1001 Unistrut or equal) to support the Center Track Bracket.

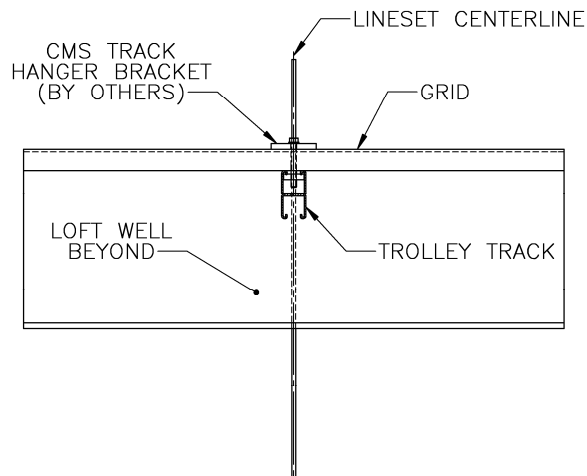

Figure 7. Grid Mounted CMS - End View



4.3 Line Shaft Rigging with out Grid

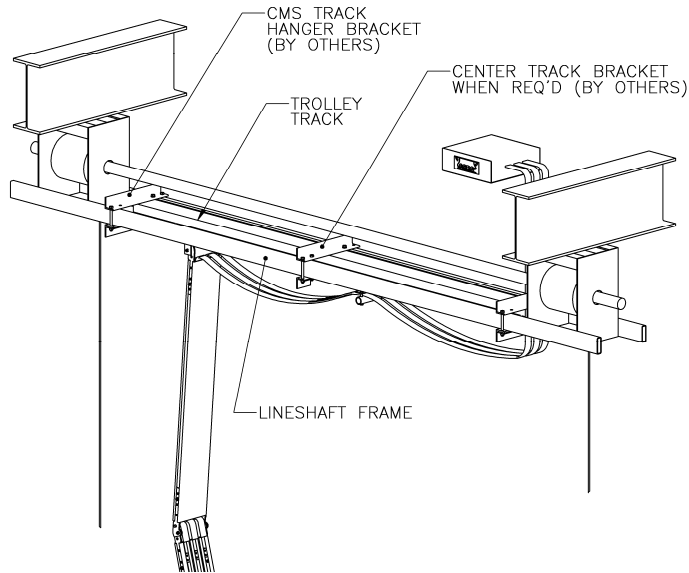

Figure 8. Trolley Track with Lineshaft Rigging

The Trolley Track must be installed in the same plane with the lifting lines of the set. See Figure 8 and Figure 9. Sandwich style brackets can be used to clamp to the horizontal framing members of the lineshaft set which in turn attach to the Trolley Track. If the lineshaft set is not supplied with horizontal members, then custom brackets to support the trolley track are required. Each track support bracket must be rated for a 500 lb working load. **NOTE:** If the weight of the CMS is in excess of 200 lbs, the Trolley Track must have an additional support at its center span. If the lineshaft set is not supplied with horizontal members, then a suspension system similar to one shown in Section 4.1 must be used to support the Center Track Bracket.

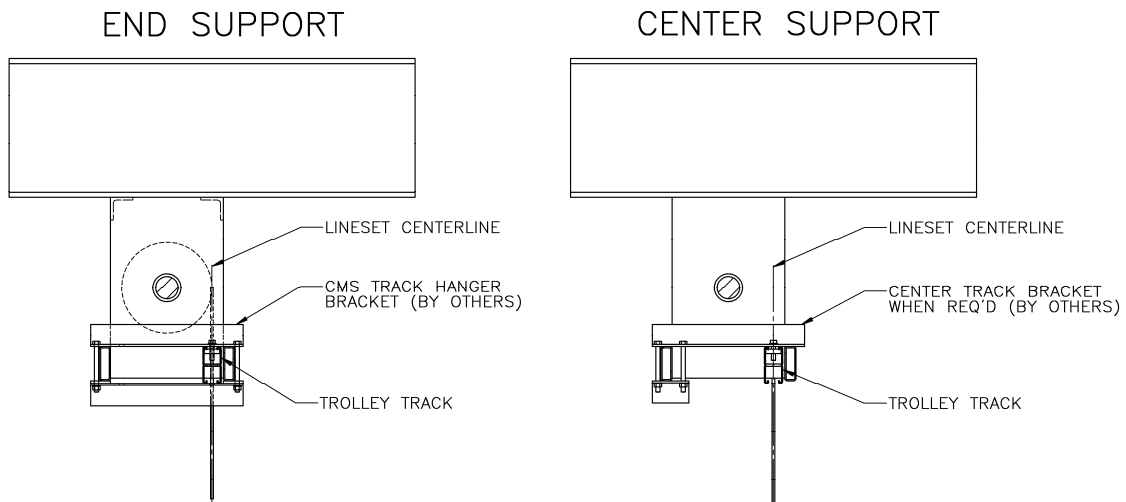

Figure 9. Trolley Track and Centerline of Set - Lineshaft Rigging



5.0 BATTEN ATTACHMENT

5.1 Double Pipe Batten

A double pipe batten is defined as two pipe battens running the full width of the rigging set and joined by connector strip brackets. See Figure 10. The lift lines attach to the top pipe or the top of the connector strip brackets. The connector strip brackets must have sufficient grip to prevent the pipes from rotating. The CMS is located between two of the lift lines.

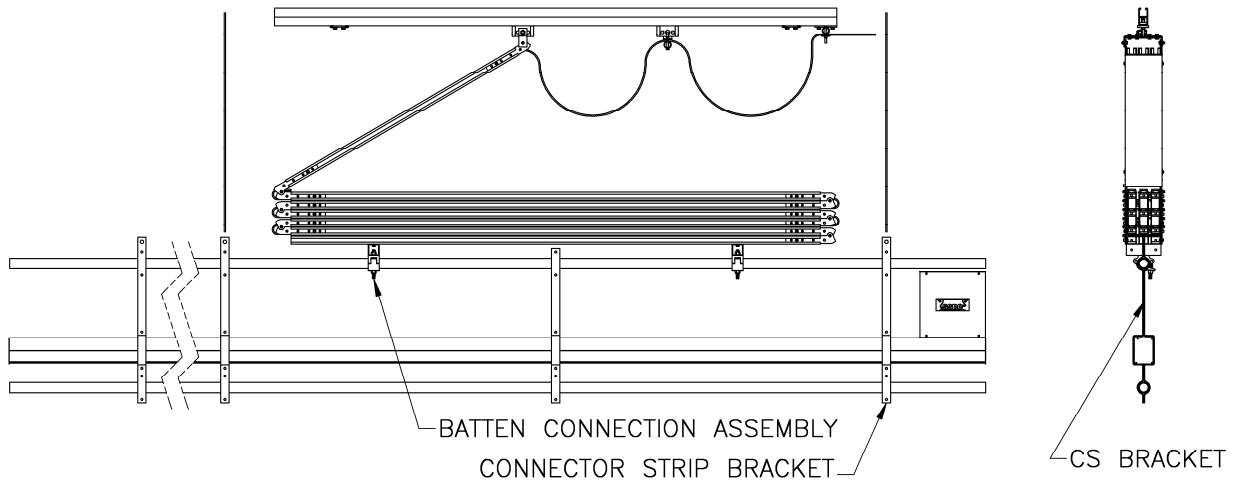

Figure 10. Double Pipe Batten

Attach the CMS to the top pipe of the batten with the clamps included in the Batten Connection Assembly. Torque the 1/2 inch nut of the clamps to 15 ft-lbs. The CMS must be clamped securely to the pipe batten so that it cannot rotate about the pipe. The top pipe batten must also be clamped via the connector strip brackets in a manner that prevents rotation.



5.2 Double Pipe Batten with Safety Guide Yokes

If the CMS has five (5) or more active full length arm sections, then Safety Guide Yokes are required. See Figure 11. The Safety Guide Yokes maintain the alignment of the CMS arm sections as they stack up when the set is being raised. They also prevent further damage if the set is lowered onto an obstruction and the batten assembly rotates out of plumb.

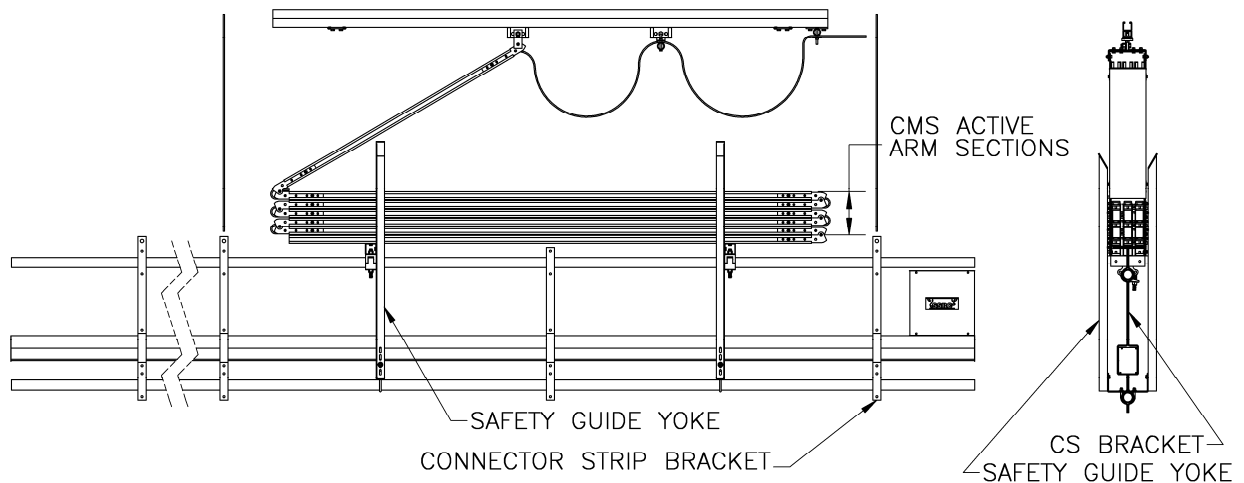

Figure 11. Double Pipe Batten with Safety Guide Yokes

The Safety Guide Yokes fasten to the square tube of the Batten Connection Assembly and the lower pipe of the double pipe batten. The lower bracket of the Safety Guide Yoke is adjustable to accommodate various pipe spacings of the double pipe batten.



5.3 Truncated Double Pipe Batten

A Truncated Double Pipe Batten is defined as a lower pipe batten running the full width of the rigging set and an upper pipe batten wide enough to attach to the connector strip brackets on either side of the CMS. See Figure 12. The two lift lines on either side of the CMS must attach to the top of special extended-arm connector strip brackets. These connector strip brackets raise the lift point of the set above the center of gravity of the CMS. This improves the stability of the CMS. They also have sufficient grip to prevent the pipes from rotating.

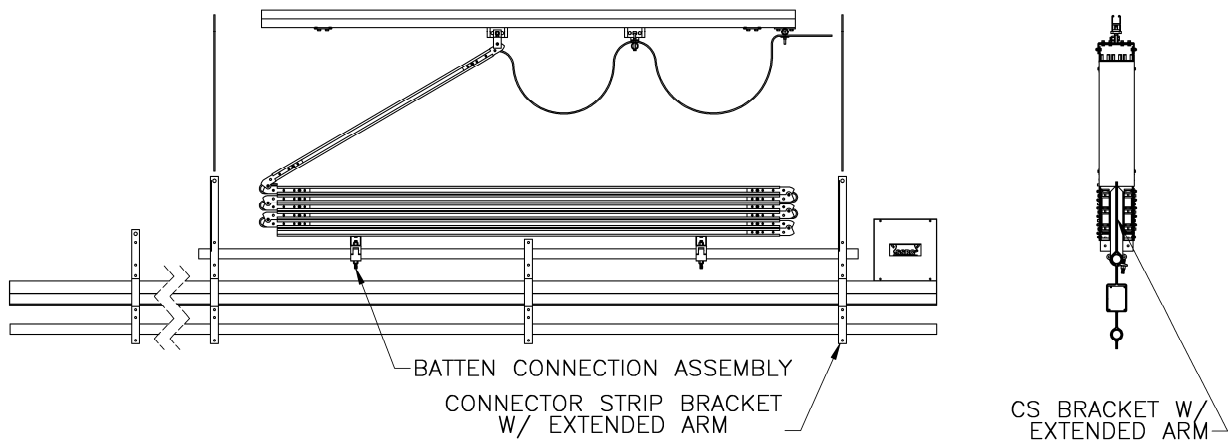

Figure 12. Truncated Double Pipe Batten

Attach the CMS to the top pipe of the batten with the clamps included in the Batten Connection Assembly. Torque the 1/2 inch nut of the clamps to 15 ft-lbs. The CMS must be clamped securely to the pipe batten so that it cannot rotate about the pipe. The top pipe batten must also be clamped via the connector strip brackets in a manner that prevents rotation.



5.4 Truncated Double Pipe Batten with Safety Guide Yokes

If the CMS has five (5) or more active full length arm sections, then Safety Guide Yokes are required. See Figure 13. The Safety Guide Yokes maintain the alignment of the CMS arm sections as they stack up when the set is being raised. They also prevent further damage if the set is lowered onto an obstruction and the batten assembly rotates out of plumb.

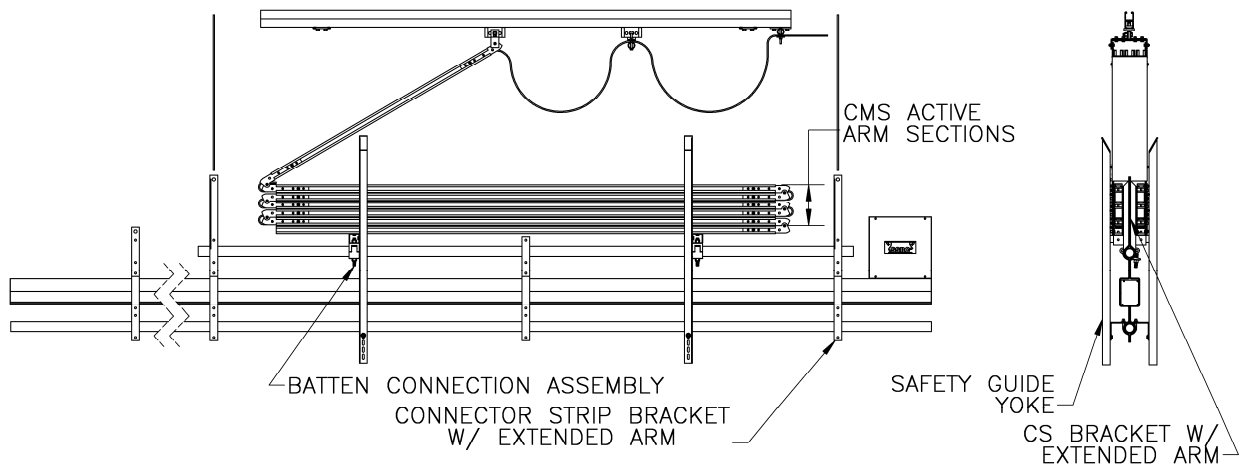

Figure 13. Truncated Double Pipe Batten with Safety Guide Yokes

The Safety Guide Yokes fasten to the square tube of the Batten Connection Assembly and the lower pipe of the double pipe batten. The lower bracket of the Safety Guide Yoke is adjustable to accommodate various pipe spacings of the double pipe batten



6.0 ADJUSTMENTS

6.1 End Stops

The End Stops on the Trolley Track must be adjusted to obtain the best performance of the CMS. If the End Stops are located too far inboard, the CMS unit will cause excessive batten sway. If they are located too far outboard, then excessive force is generated as the unit is raised and it folds each successive section. The End Stops always need to be located inboard of the pivot points of the CMS. Typically, the End Stop on the side opposite the Festoon should be 12 inches from the pivot point on this side. This is the left hand End Stop shown in Figure 14. The End Stop on the Festoon side should be 8 1/2 inches from the pivot point on this side. This accounts for the space the Festoon Trolley occupies and maintains equal stop points for the CMS Trolley. The upper limit of the rigging set should be adjusted so that the swags of the Festoon Portion of the Upper Tail do not foul or touch the CMS arms.

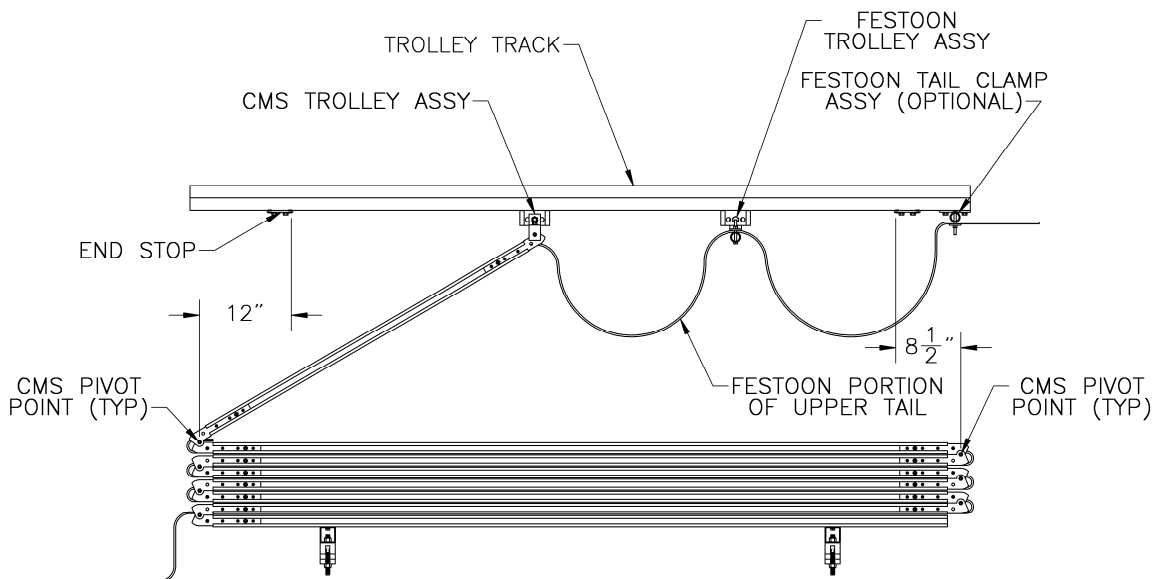

Figure 14. CMS in Up Position

6.2 Festoon – Extended

Lower the batten until the CMS Trolley is up against the End Stop opposite the Festoon direction. See Figure 15. Move the Festoon Trolley to a position at the center of its travel. Adjust the swags of the flat festoon cables so that they are equal on each side of the Festoon Trolley. They should drape approximately 4 to 5 inches. Secure the end of the Festoon Portion of the Upper Tail with the Festoon Tail Clamp Assembly or other suitable means. The end of the Festoon Portion must be adequately clamped so that it does not limit the travel of the CMS Trolley.

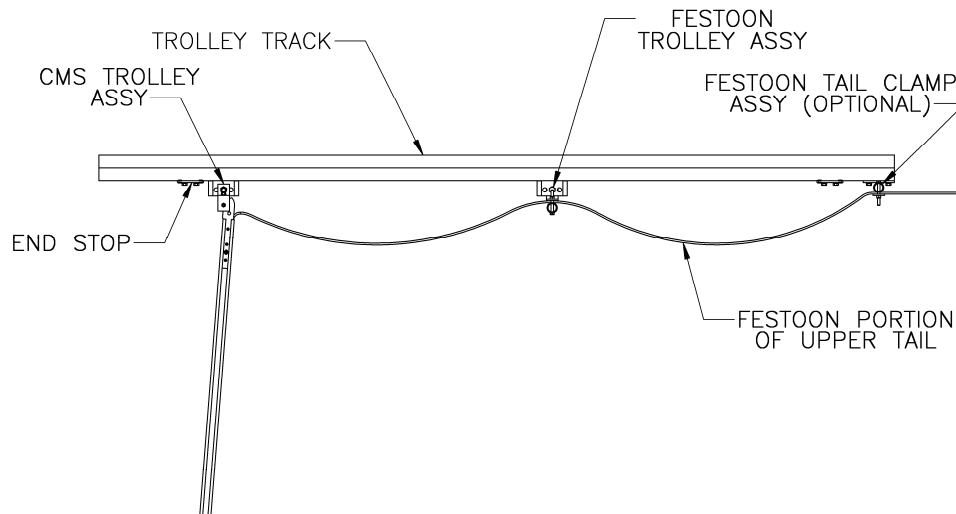

Figure 15. CMS with Festoon Cables Extended

6.3 Festoon – Retracted

After the previous adjustments are made, move the batten through its range of travel and ensure the CMS Trolley and Festoon Trolley move smoothly in the track. Make sure the trolleys travel the full range of motion between the stops. Make sure the festoon cables loop nicely in even swags. See Figure 16.

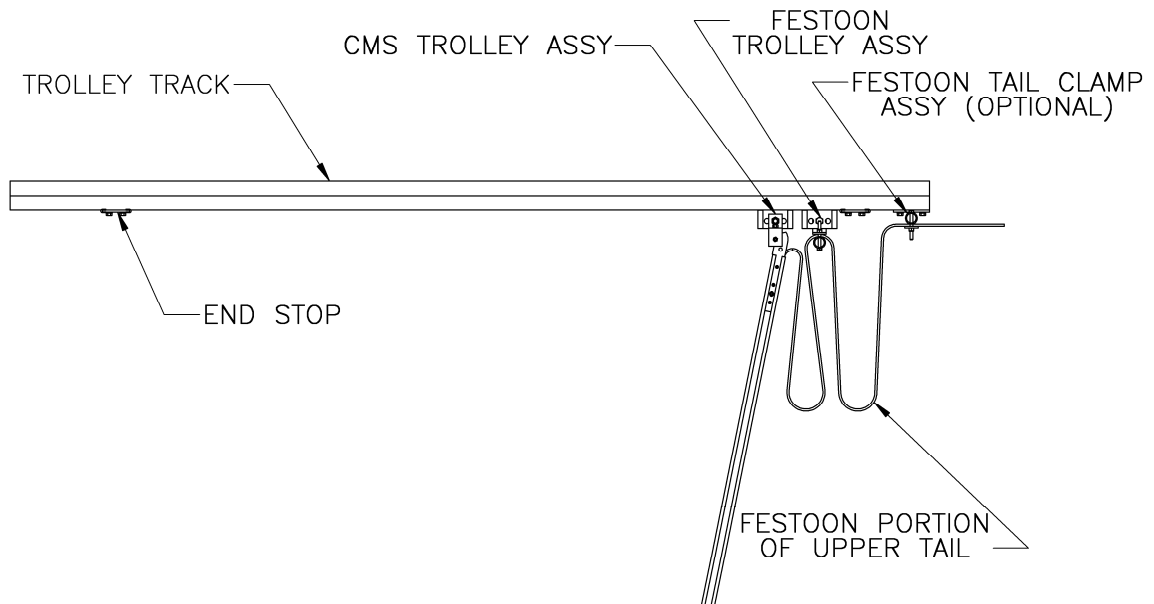

Figure 16. CMS with Festoon Cables Retracted



6.4 Contacts

Please contact SSRC with questions you may have regarding the installation of the CMS Pantograph products.

SSRC, Inc.
170 Fortis Dr.
Duncan, SC 29334

Telephone number 864-848-9770
Fax number 8648483746

Our web address is, www.ssrconline.com