

Spotlight Cage

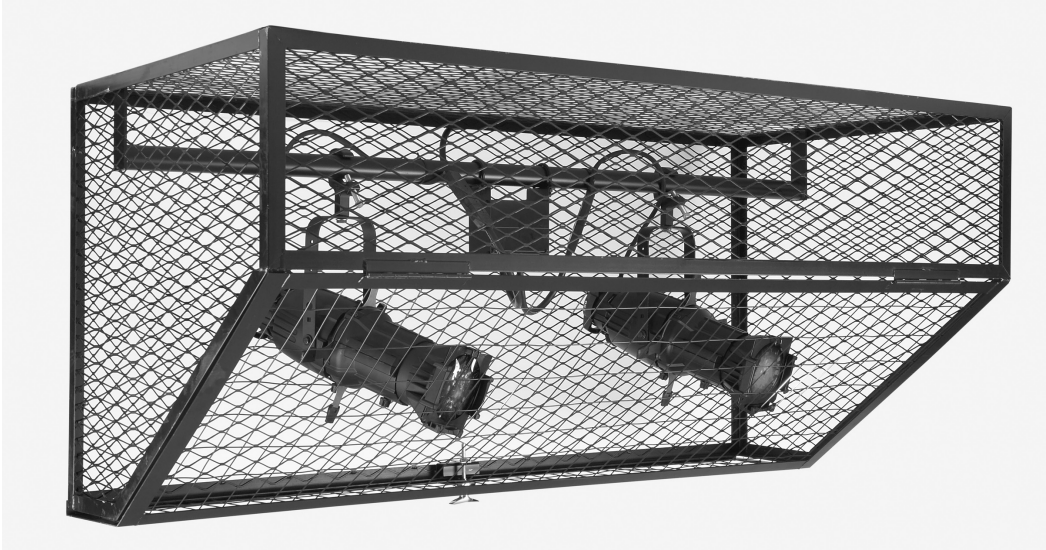

For use in gymnasiums or multipurpose rooms to protect light fixtures from damage.

Welded angle iron frame.

1/2" expanded metal sides.

2" X 4" wire mesh on hinged door.

1 1/2" schedule 40 steel pipe included for fixture hanging.

Can be hung directly from structure, from threaded rod or from chain or cable.

Available in two frame sizes (S or L) depending on fixture length.

Available in six standard lengths.

Model #	Spotlights	Length of Cage	A	B	C	D	E
ASL2-S	2	48"	34"	9"	33"	10"	15"
ASL3-S	3	60"	34"	9"	33"	10"	15"
ASL4-S	4	72"	34"	9"	33"	10"	15"
ASL3-L	3	66"	42"	12"	39"	18"	21"
ASL4-L	4	84"	42"	12"	39"	18"	21"
ASL-6-L	6	96"	42"	12"	39"	18"	21"

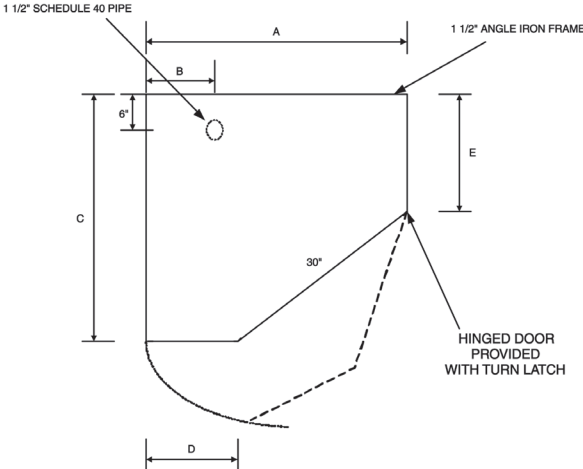

Optional Features

Available with pipe mounted outlet box or connector strip.

Available in custom finish and sizes.